

**BODY SET**

**REFRIGERATING AND ELECTRIC SET**

Position	Description	Reference
<b>Electrical spare parts</b>		
64	Ventilation motor (CAE 310, 507, 508 3 ph.)	WLS01689
	Ventilation motor (CAE 506 and 508 sing.ph.)	WLS01688
	Ventilation motor (CAE 517, 510 3 ph.)	WLS01690A
	Ventilation motor (CAE 722, 513 3 ph.)	WLS01691A
121	Extractor sensor	WCE01311
127	Remote relay 220 Volts	WCF02710
127	Remote relay 12 Volts	WFD01460
128	Digital regulator EC 6 133 with sensor (condenser option)	WCE02685
129	Regulator ECP 600	WCE06000
130	Thermal circuit breaker PKZMO 16 A	WCF01078
	Thermal circuit breaker PKZMO 2.5A	WCF01074
	Thermal circuit breaker PKZMO 4A	WCF01075
	Thermal circuit breaker PKZMO 6.3 A	WCF01073
133	Phase controller (CAE 3 phase)	WCZ01371
177	Defrosting sensor (grey)	WCE01312
	Compressor capacitor 50 $\mu$ f (CAE 506)	B0181100A
	Compressor capacitor 55 $\mu$ f (CAE 508)	B0181700A
B	Standard wall hygrostat	WCE01314
C	Hygro control + sensor **	WD000001
	Hygro control sensor	WCE03431
D	Static timer 180S	WCZ01370
F	Transformer 220/12V	WSE01929
G	Extractor thermostat (condenser option)	WIN01644
H	Auto rearming safety thermostat	WIN01642
I	Manual rearming safety thermostat	WIN01646
	DILM 9-10 contactor (give model)	WCF01066
	Heater 1.5 kW	WRI01892
	Standard wall hygrostat	WCL01318
<b>Refrigerating spare parts</b>		
71	Compressor ZR 34 sing.ph. (CAE 506)	WCO02581
	Compressor ZR 40 sing.ph. (CAE 508)	WCO02590
	Compressor ZR 40 3 ph. (CAE 507, 508)	WCO02687
	Compressor ZR 61 3 ph. (CAE 510)	WCO02453
	Compressor ZR 81 3 ph. (CAE 513)	WCO02688
74	Expansion valve TX3 N36 (CAE 506)	WAC02499
	Expansion valve TX3 N37 (CAE 508)	WAC02500
	Expansion valve TX3 N38 (CAE 510)	WAC02501
	Expansion valve TX3 N39 (CAE 513)	WAC02753
76	Liquid indicator 33S (CAE 506, 508)	WCY01000
	Liquid indicator 34S (CAE 510, 513)	WCY01001
78	Dehydrator 083S (CAE 506, 598)	WCY00996
	Dehydrator 164S (CAE 510.513)	WCY00998
117	LP pressure switch* 0.5/2 bars	WJC01668
118	HP pressure switch* 20-26 Bars	WJC01669
<b>Others</b>		
65	Turbine (CAE 506, 508)	WNI01742
	Turbine (CAE 510, 513)	WNI01743
	Turbine bearing (CAE 506, 508)	R06217
	Turbine bearing (CAE 510, 513)	R06218
68	Ventilation belt (CAE 517, 722*)	WRS01894
	Ventilation belt (CAE 310, 506, 507, 508, 510, 513*)	WGA02968
	Condensation collector*	WTP02122
70	Ambient filter frame (CAE 506, 507, 508, 510, 513*) size 375 x 445 x 20 mm (2 unit to order)	WSD01908
	Rear filter frame (CAE 506, 507, 508, 510, 513*) size 788 x 400 x 23 mm	WSD01910
	Side filter frame (CAE 506, 507, 508, 510, 513*) size 555 x 455 x 23 mm	WSD01909
	Bumpy foam insulation m <sup>2</sup> (plate dimension 1,50 m x 1,00 m)	WCA02600
	Filtering medium without frame (CAE 310, 517, 722*)	WTC03077
167	Silent block M/F motor fan bracket	WGA02946

A

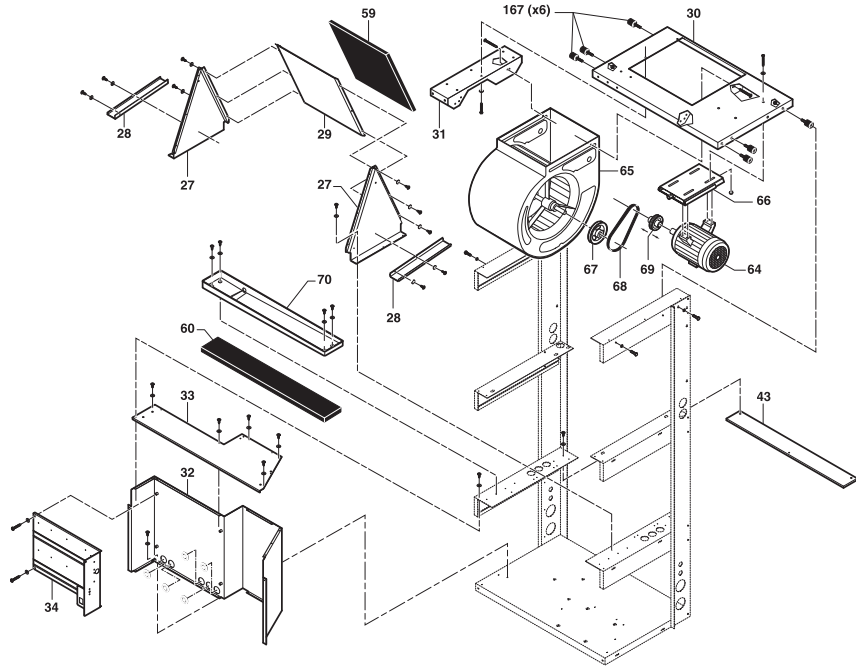
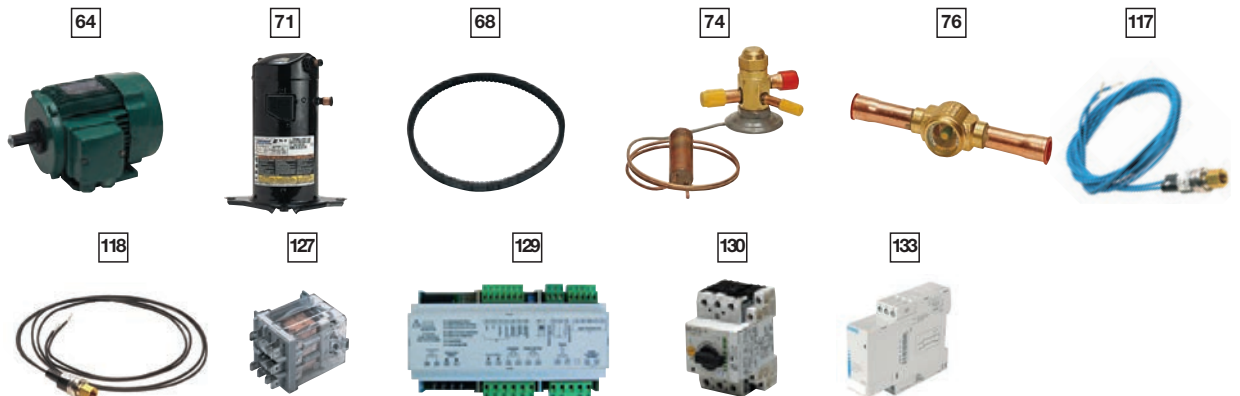
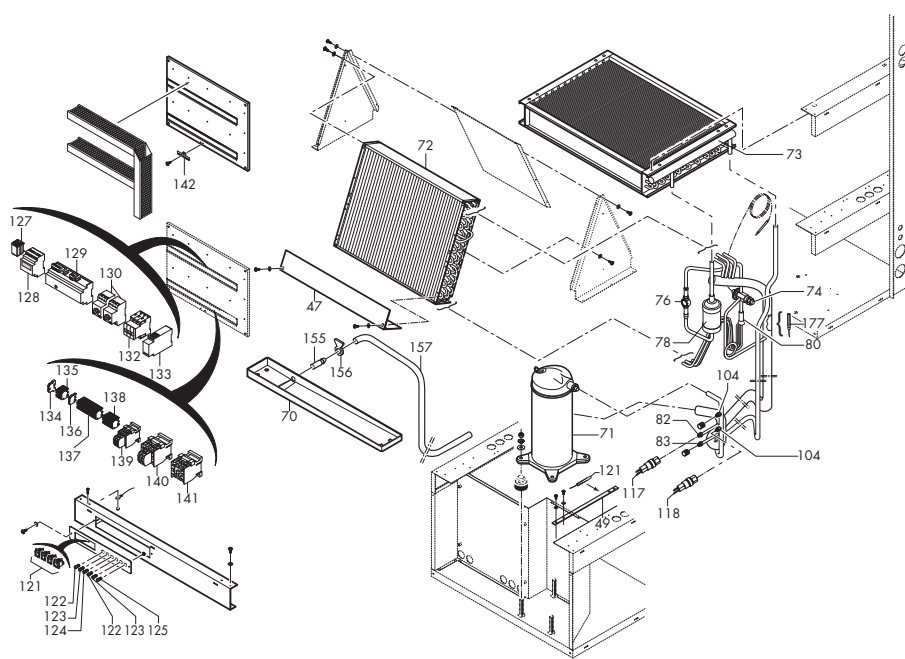
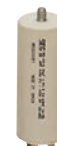

B



C



Replaced by



D



E



F



G



H



I

