

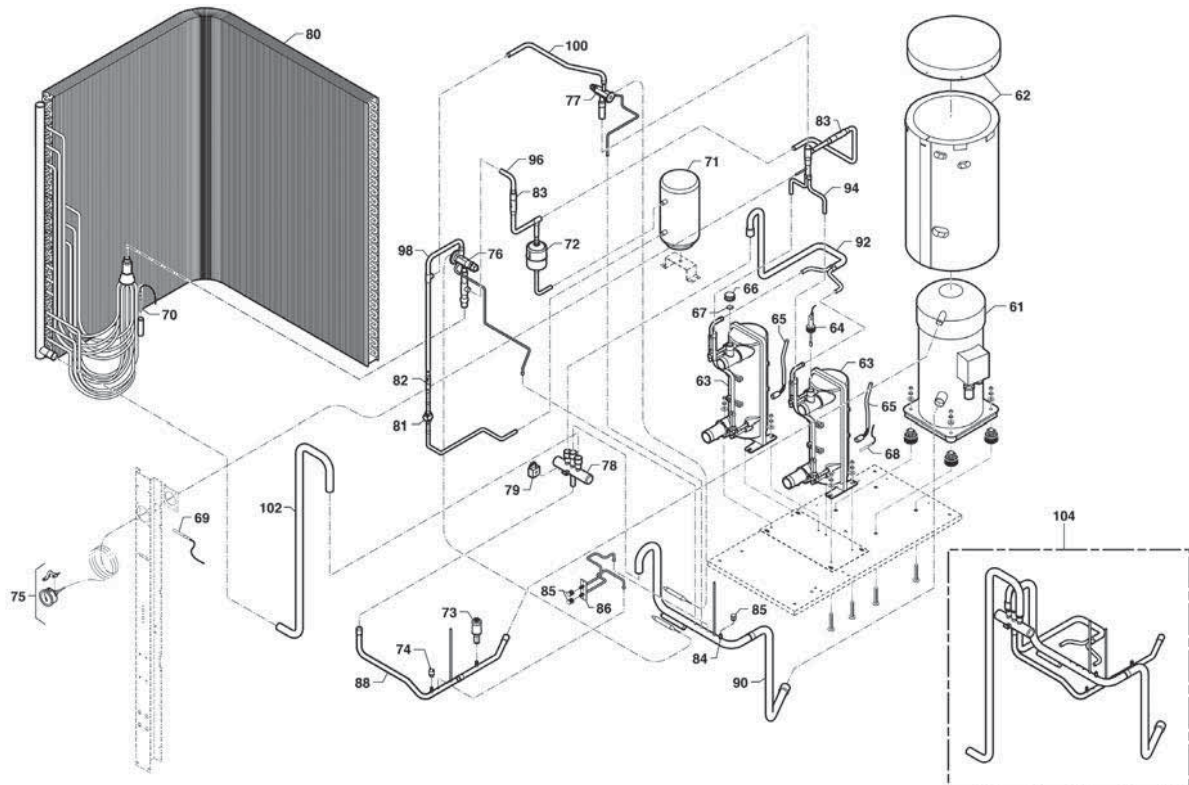

Optipac 2, 3, 4, 7, 10, 15, 15D, 30 & 30D

Spare Parts



Position	Description	Reference
Electrical spare parts		
12	Ventilator motor 150W (OPTIPAC 2, 3, 4, 7*)	WTC02143
	Ventilator motor 378 W (OPTIPAC 10)	WTC02142
	Ventilator motor 530W (OPTIPAC 15 and 30)	WTC02144
64	Noryl flow switch	WSK02022
47a	Timed regulator ECP 331 (2000 to 2003 model)	WCE01309
47b	Timed regulator ECP 231 (before 2000)	WCE01306
A	Euro alpha FK (MAP1) regulator (2004)	WCE03688
B	Euro alpha FK A1 plate (Optipac) (since 2004)	WCE03553
C	Euro alpha FK connection plate for OPTIPAC 30 and 15D (since 2007)	WCE03698
	EVK Regulator for Optipac 15D & 30D (since 2011)	WCE03823
	EVK Connection braid for Optipac 15D & 30D (since 2011)	WCE03824
D	EVK connection plate for Optipac 15D & 30D (since 2011)	WCE03825
	Euro alpha FK connection braid	WCE03554
	Compressor contactor* (OPTIPAC 2, 3 single 7 three phase) 18A	WTC03085
53	Compressor contactor* (OPTIPAC 3, 4 three phase) 9A	WTC03086
	Compressor contactor (OPTIPAC 15/30) 32A	WTC03087
	Compressor contactor (OPTIPAC 10)	WTC03088
54	Fan contactor* (OPTIPAC 2, 3, 4, 7) 9 A	WTC03089
	Compressor contactor* (OPTIPAC 3, 4 three phase) 9A	WTC03086
59	Compressor capacitor 50µf (CAE 506)	B0181100A
	Compressor capacitor 55µf (CAE 508)	B0181700A
60	Fan capacitor 4 µF (OPTIPAC 2, 3 and 7)	WSG01938
	Fan capacitor 5 µF (OPTIPAC 4)	WCE03714
65	Defrosting sensor (grey)	WCE01312
68	Extraction sensor	WCE01311
E	NTC sensor for euro alpha FK (water, anti-freeze or defrosting temperature)	WCE03850
F	NTC sensor for euro alpha FK (water, anti-freeze or defrosting temperature)	
G	Phase controller	WCZ01371
	Starter relay SPP5	WGF02960
	Anti-freeze thermostat (with ECP 231)	WIN01645
	4-way valve coil Optipac 15 and 30D	WTC03836
	Transfo 400/230 V Optipac 15/30	R06708

Position	Description	Reference
Refrigerating spare parts		
32	Compressor ZR 34 sing.ph. (CAE 506)	WCO02581
	Compressor ZR 40 sing.ph. (CAE 508)	WCO02590
	Compressor ZR 40 3 ph. (CAE 507, 508)	WCO02687
	ZR48 Compressor 407C (OPTIPAC 4)	WCO02589
	Compressor ZR81 3 ph. (OMEGA 16)	WCO02688
	SZ100 Compressor S4VA 407C (OPTIPAC 10)	WTC02864
	Compressor MS161 S4AM 407C (OPTIPAC 15/30, 15D and 30D)	WTC02138
33	HP Pressure switch* 20-26 B	WJC01669
	LP Pressure switch* 0.5/2 B	WJC01668
35	Expansion valve TX3 N36 (CAE 506)	WAC02499
	Expansion valve TX3 N38 (OMEGA 10)	WAC02501
	Expansion valve OPTIPAC 2 and 3 (BIVE-2-1/2-GA-B15) SPORLAND before 2003	WTC03886
	SPORLAND Expansion valve OPTIPAC 4 (EFVE-3-CP100)	WTC03887
	SPORLAND Expansion valve OPTIPAC 7 (SVE 4 CP100)	WTC03110
	SPORLAND Expansion valve OPTIPAC 10, 15 and 30	WTC03888
	Expansion valve TX7N15 (OMEGA 20 and 28)	WAC02961
42	Dehumidifier 053S (OPTIPAC 2, 3, 3D)	WCY00995
	Dehumidifier 084S (OPTIPAC 4, 7D)	WCY00997
	Dehydrator 164S (OMÉGA 10, 14, 16)	WCY00998
45	Liquid indicator 34S (OMEGA 10 to 16)	WCY01001
45	Flow manometer with capillary 407C	WTC03084
	Condensor MD8 TD8	R06957
	Flexible inlet manifold	W20COLPAC30EN06
	Flexible outlet manifold	W20COLPAC30SO06
	Flexible manifold bracket	WTC04006
Others		
72	Regulator access window	WTC02172
13	Fan* (OPTIPAC 2, 3, 4, 7)	W20HELI
23 / 24	Set of 2 half-union connectors + gaskets 40/49	W20RDU
23	Joint for 50 x 1' 1/2 union	WNS03428
26	Polyamide glove finger 1»	WIB01635
	Condenser connection 7M without fixture (water inlet)	WIB01634
	Condenser connection 7M without fixture (water outlet)	WIB01633
21	24/31 joint thickness 4	WJW01665
	Anti vibration pegs (to order by 4)	WAP03064
100	Quarter turn plastic button	WTC02171
	2 1/2 union connectors Ø 63 (OPTIPAC 10 15)	W20RDU1
	Plastic grooved condensation angle + cap	WKITCONDENSAT
	Water condenser 7M kit (bolt + spire support + joint)	WKITGELCOND7M
	Condenser outlet connector with tapping+gasket (before 2016)	R0611001
	Condenser inlet connector with tapping+gasket (before 2016)	R0611301
	Union connection 3 pieces diam 90 Optipac 30	WIP03450
Accessories		
	Remote control module EVK	WCE03827
	Cleaning Kit PAC NET	WMA03491

* All electric parts on single phased Heat Pumps are sold without condensers.





Optipac Defrost

Spare Parts

Description	Reference
Electrical spare parts	
Euro alpha FK speed regulation module (since 2004) ventilator 500W A2	WCE03576
Euro alpha FK A1 plate (Optipac) (since 2004)	WCE03553
NTC sensor for euro alpha FK (water, anti-freeze or defrosting temperature)	WCE03850
Euro alpha FK connection braid	WCE03554
Regulator μ chiller (before 2004)	WTC02154
Ventilation plate μ chiller A1 (before 2004)	WTC03604
Connection plate μ chiller A2 (before 2004)	WTC03603
Regulator sensor μ chiller (before 2004)	WTC03090
Refrigerating spare parts	
Expansion valve TX3 N37 (CAE 508)	WAC02500
Expansion valve TX3 N36 (CAE 506)	WAC02499
Expansion valve TX3 N39 (OMEGA 14/16)	WAC02753
4 channel vane kit (Optipac 3D)	WTC03834

* All electric parts on single phased Heat Pumps are sold without condensers.

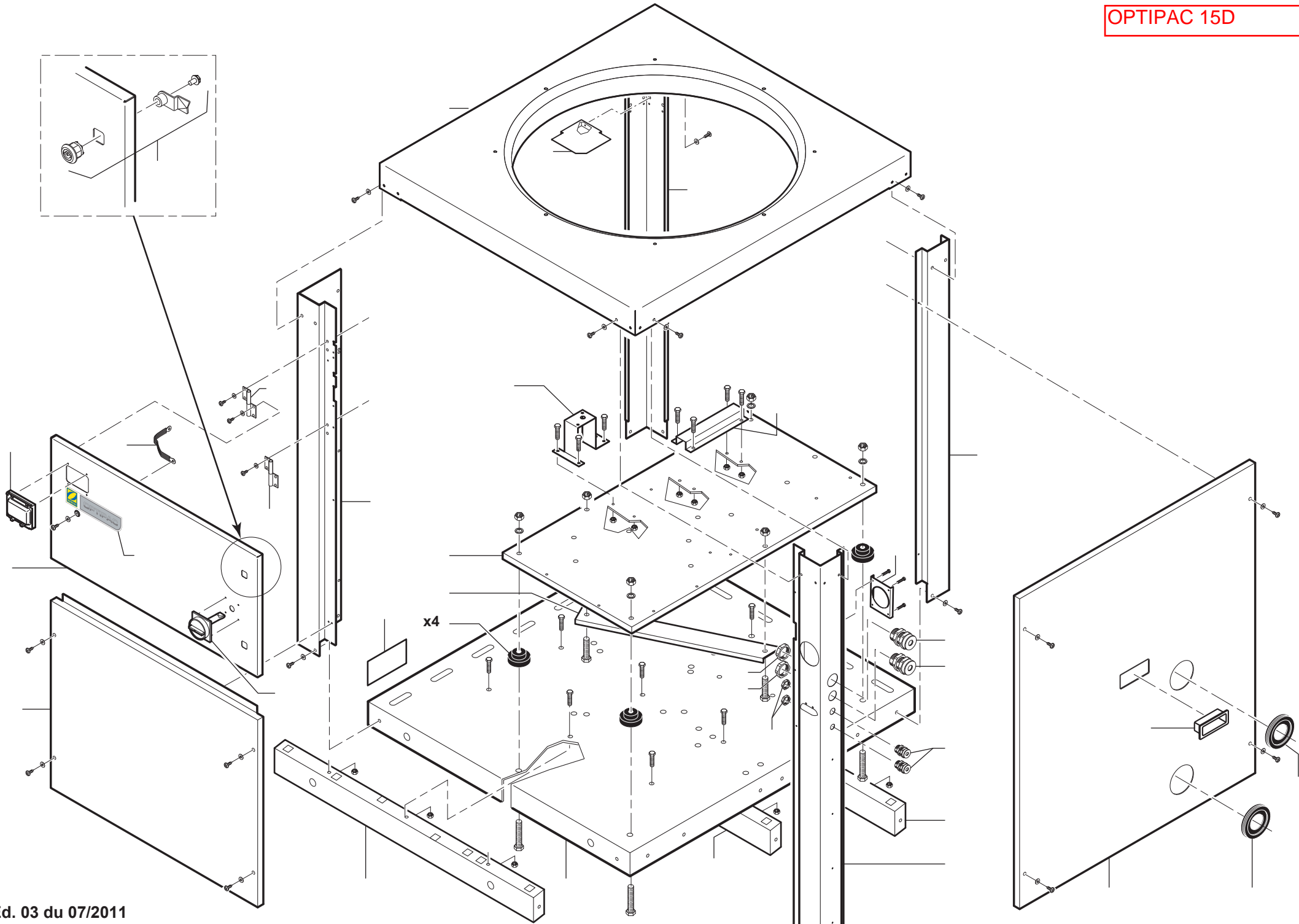

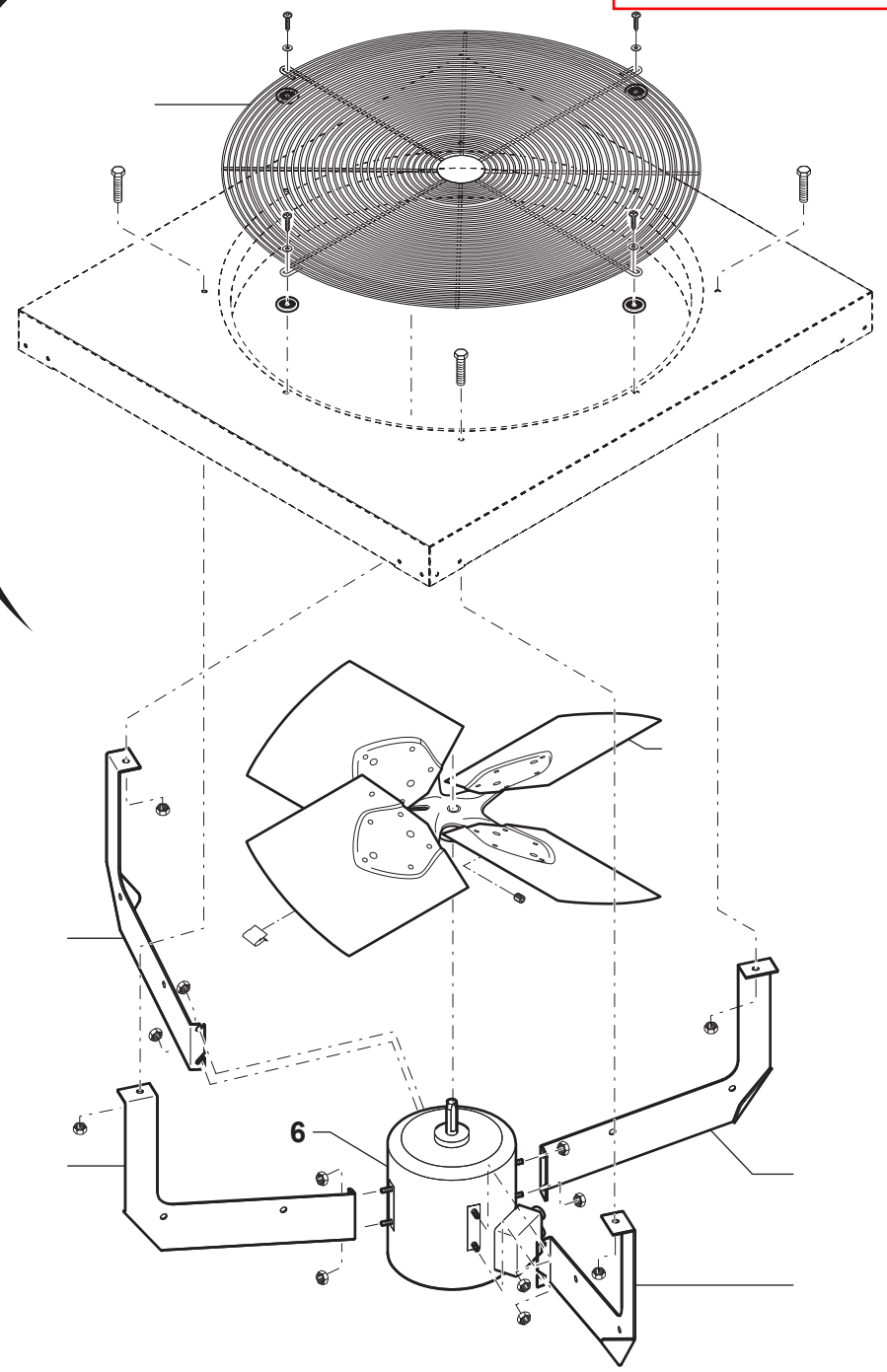
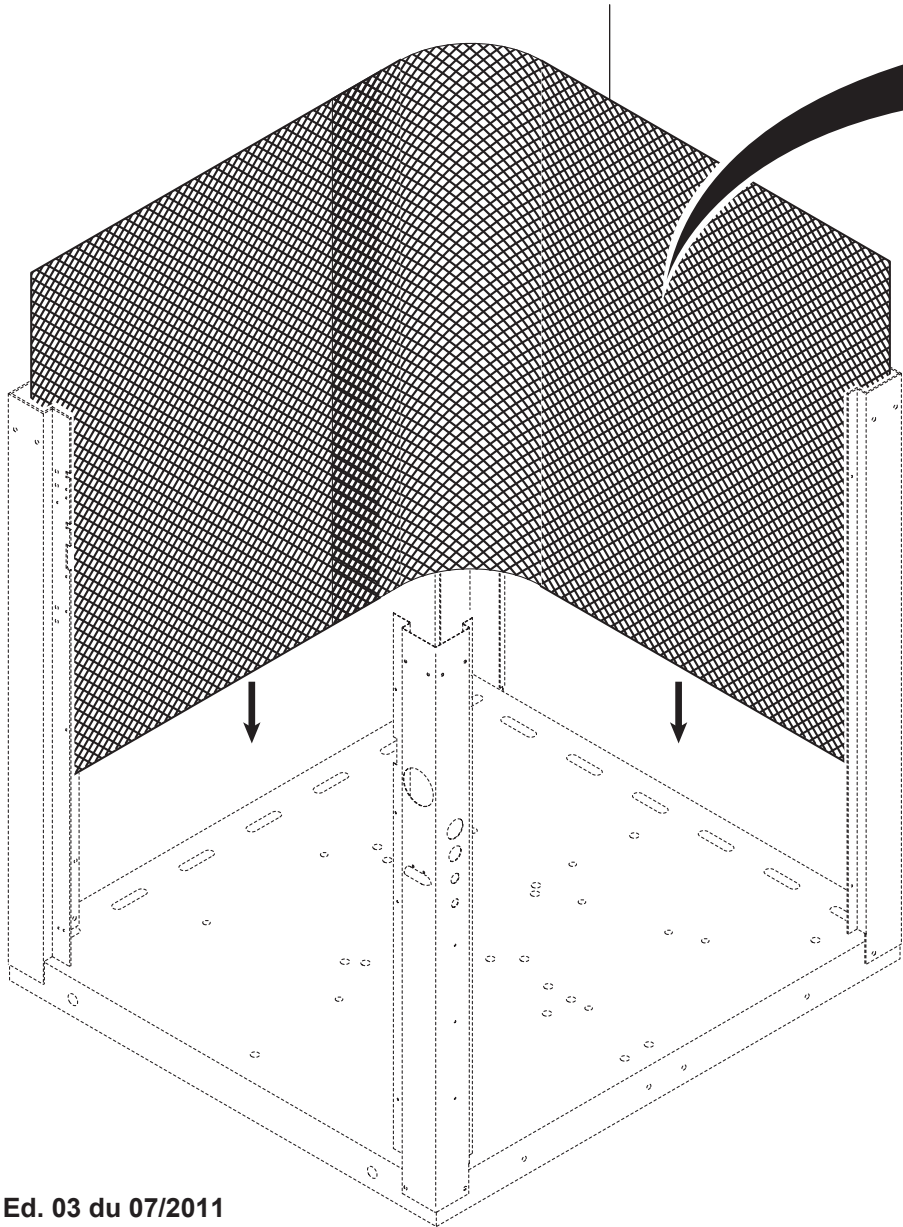

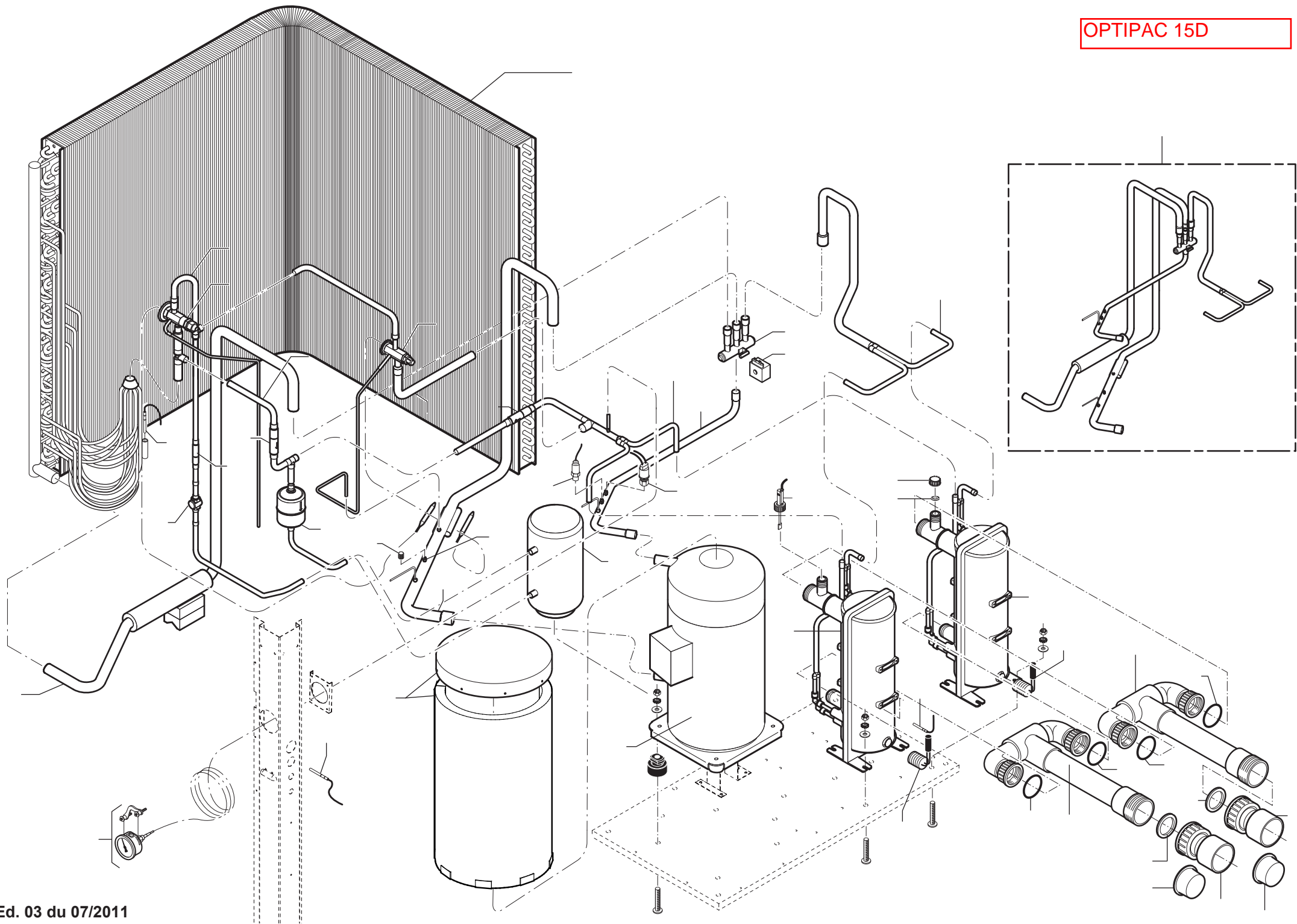

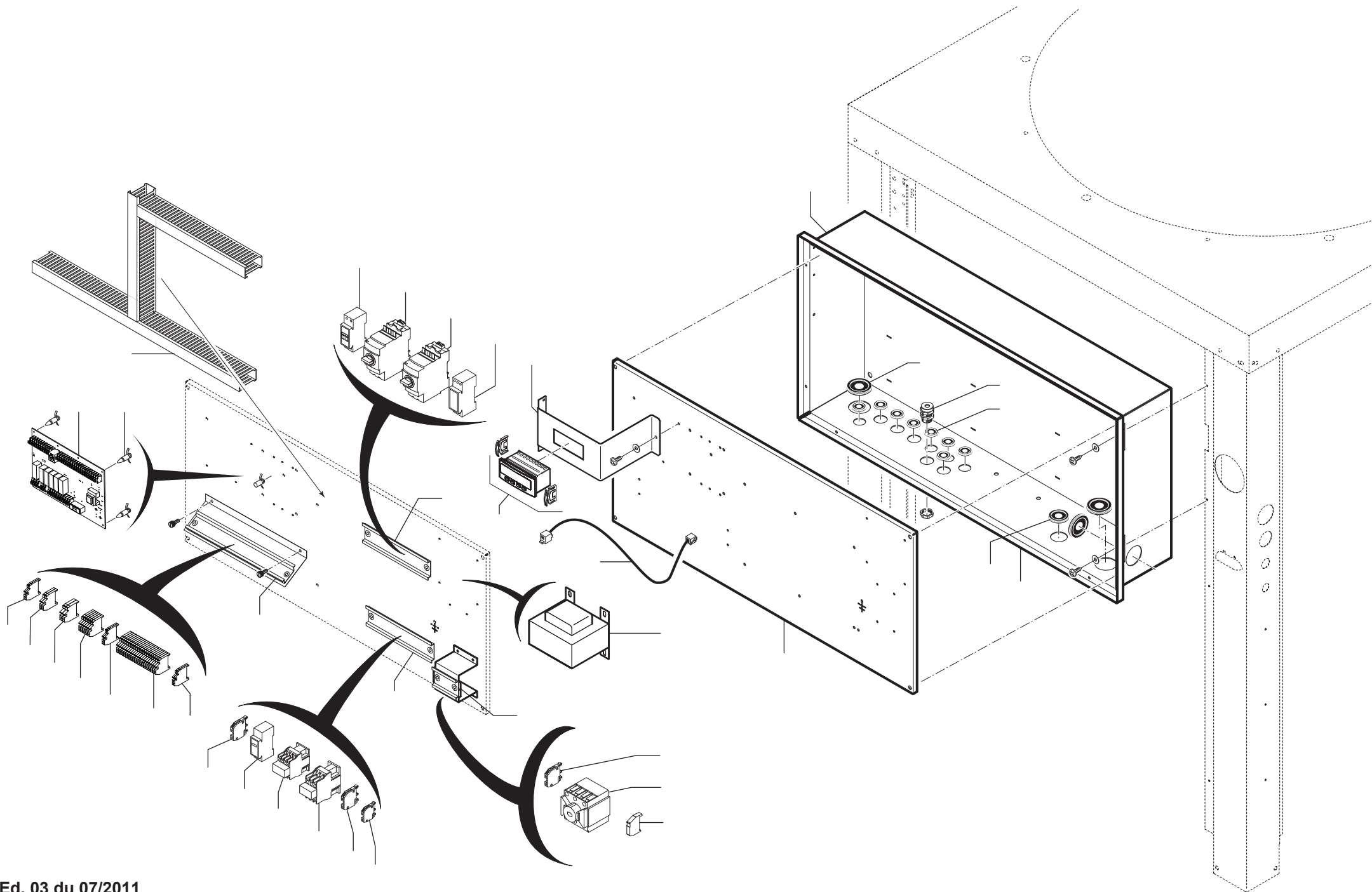

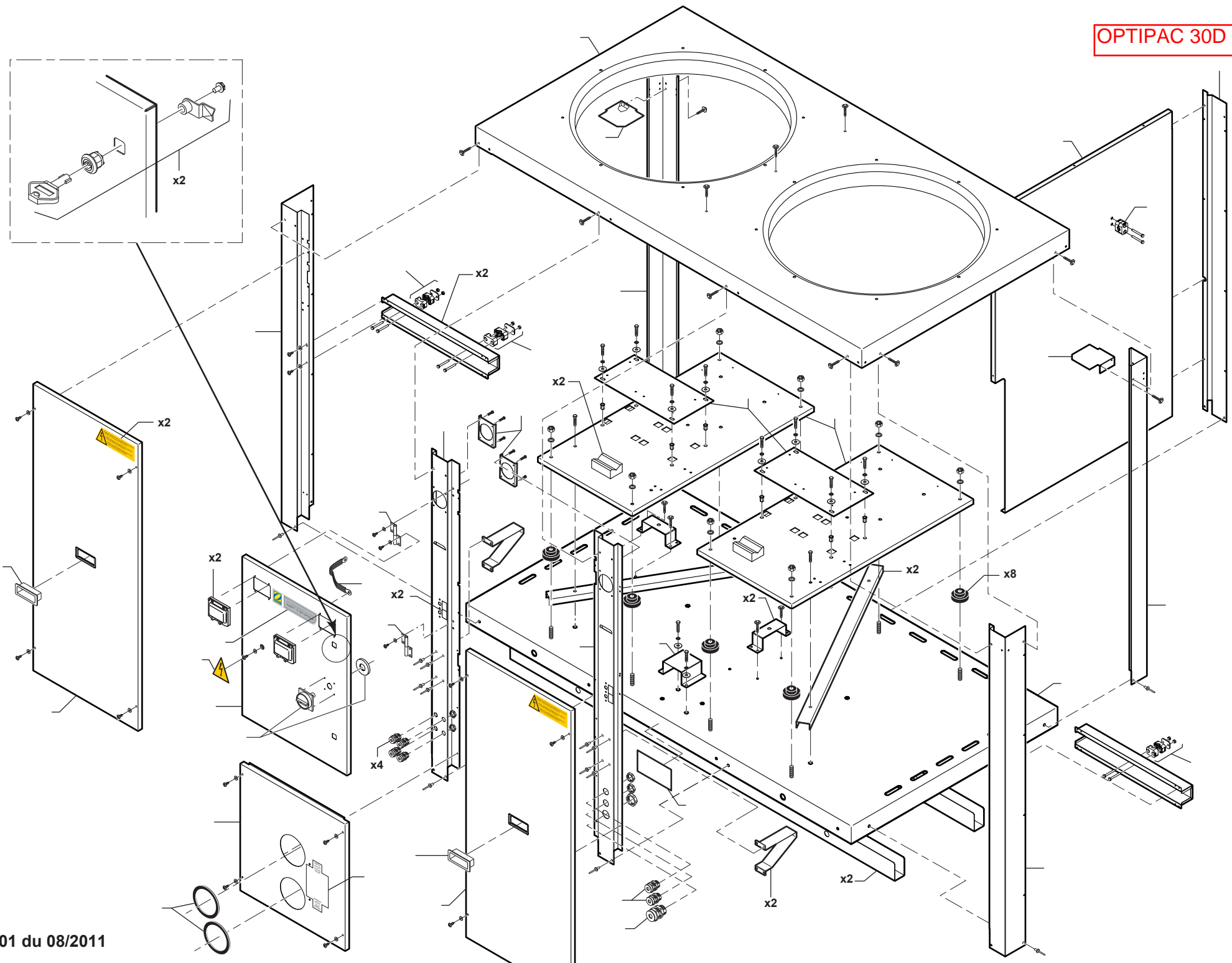

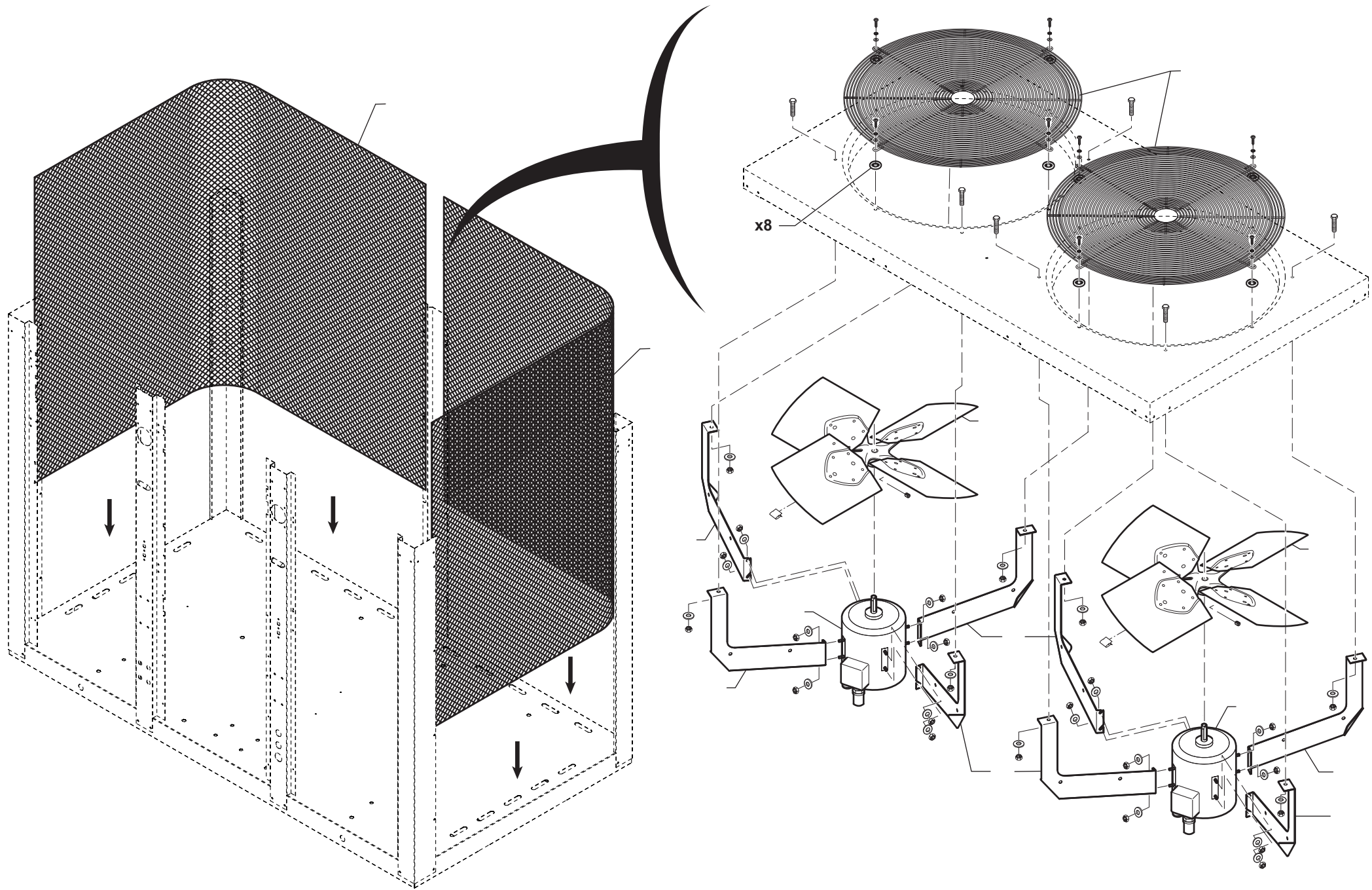

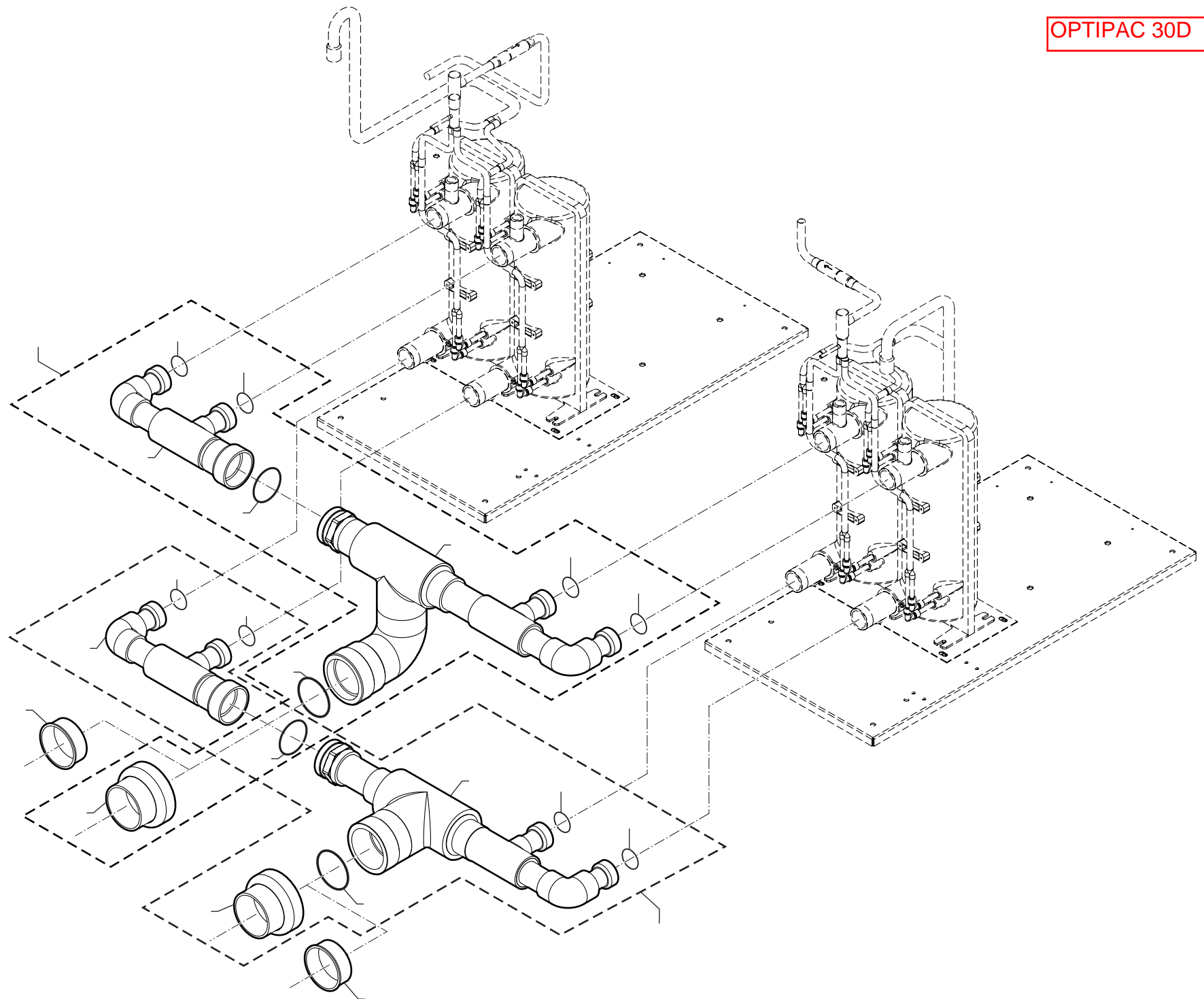

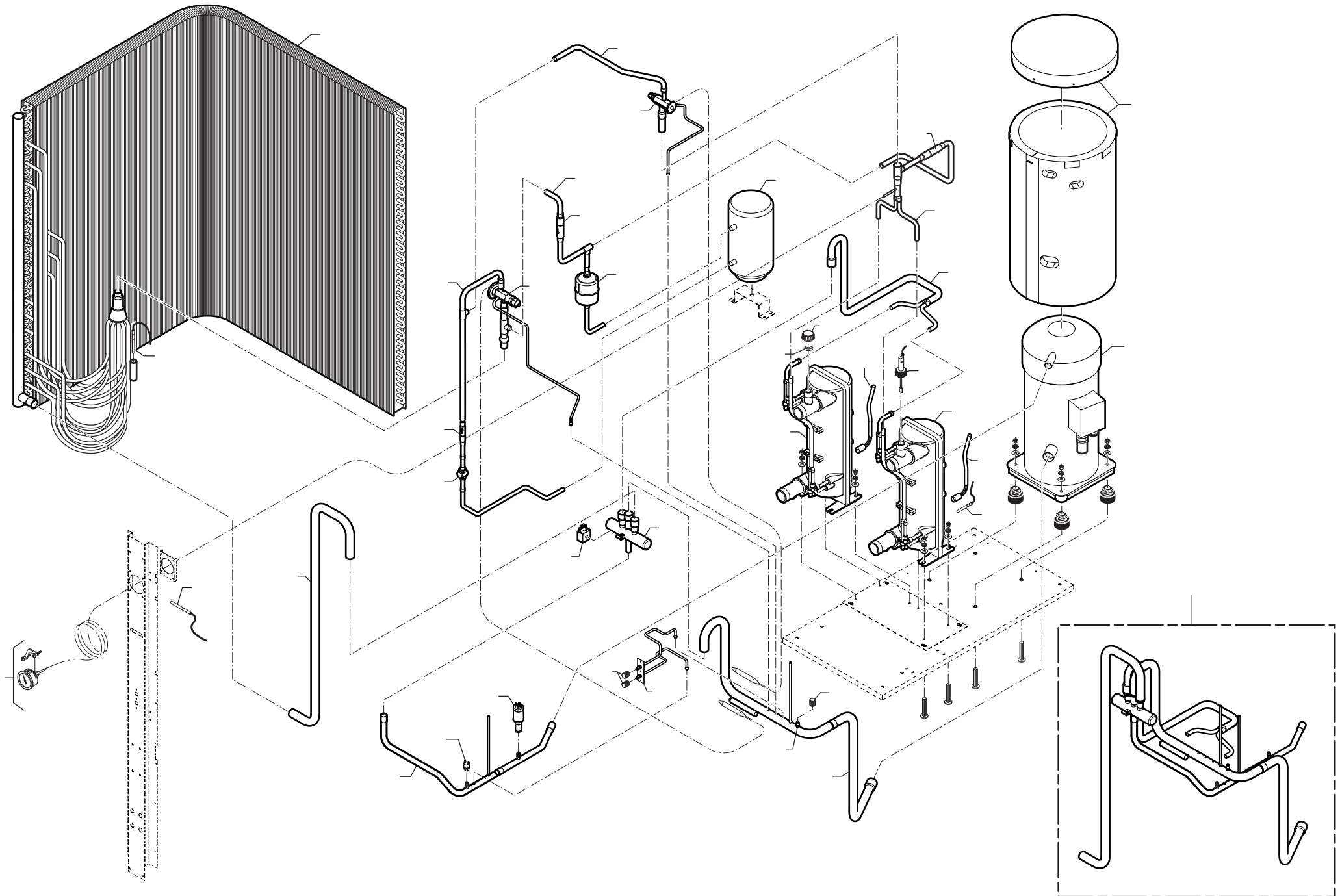

OPTIPAC 30D

